

# FMTD60-O

## Forbes Marshall Thermodynamic Trap

### Description

Forbes Marshall Thermodynamic Trap, FMTD60-O, with inbuilt strainer and full stainless steel construction is best suited for header and mainline drains and drip legs.

### Size and End Connections

1/2" Screwed BSPT / NPT

### Operating Range

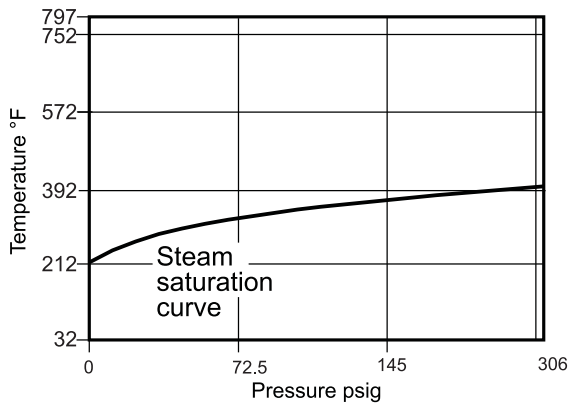

### Limiting Conditions

PMO-Maximum operating pressure	306 psig
TMO-Maximum operating temperature	797°F
Cold hydraulic test pressure	609 psig
Minimum pressure for satisfactory operation	3.6 psig
PMOB-Maximum back-pressure should not exceed the inlet pressure.	80% of

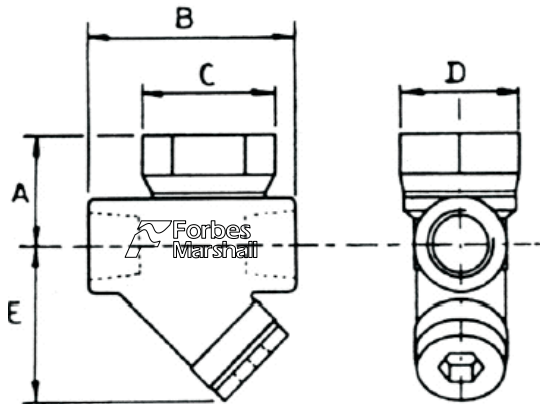

### Dimensions (approx. in inches)

Size	A	B	C	D	E	Wt. Lbs.
1/2	1.3	2.4	1.6	1.4	1.8	1.1

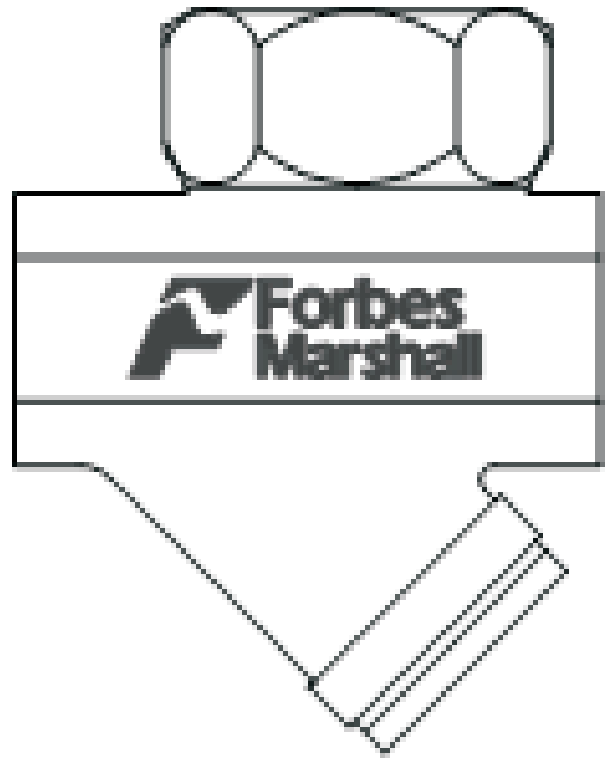

### Material

No	Description	Material	Standard
1	Body	St. Steel	ASTM A743 Gr. Ca40
2	Cap	St. Steel	ASTM A743 Gr. Ca40
3	Disc	St. Steel	ASTM A743 Gr. Ca40
4	Strainer Screen	St. Steel	ASTM A240 Type 304
5	Strainer Cap	St. Steel	ASTM A743 Gr. Ca40

### Capacities

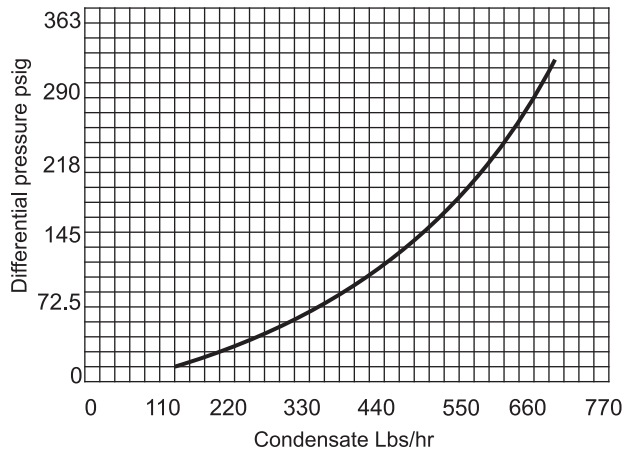

### Installation

Preferably in horizontal pipe with the disc on top. Can be fitted on other positions if unavoidable.

### How to Service

Unscrew the cap using a spanner (1 7/16"). Do not use wrenches which may cause damage to the cap. If the disc and body seating faces are only slightly worn they can be resurfaced by lapping individually on a flat surface such as a surface plate. A figure of eight motion and a little grinding compound gives best results.

If the wear is too great to be rectified by simple lapping, the seating face on the body must be ground flat and then lapped and the disc replaced by a new one. The total amount of metal removed in this way should not exceed 0.010".

When reassembling, the disc is normally placed in position with the grooved side in contact with the body seating face. Screw on the cap, no gasket is required but suitable high temperature anti-seize grease should be applied to the threads.

### How To Clean Or Replace The Strainer Screen

Unscrew the strainer cap using an allen key (15/32"). Withdraw the screen and clean or if damaged replace with a new one. To reassemble, insert the screen in the strainer cap and then screw the cap in its place. No gasket but a fine smear of a suitable anti-seize grease should be applied to the threads.

### Available Spares

The parts available as spares are shown in heavy outline. Parts drawn in dotted line are not available as spares

Disc (packet of 5)	A
Strainer Screen (Packet of 5)	B

### Recommended Tightening Torques

Sr. No.	A/F Size	Torque(Ft-Lbs.)
1	1 7/16"	132-147
2	1 7/32'	125-140

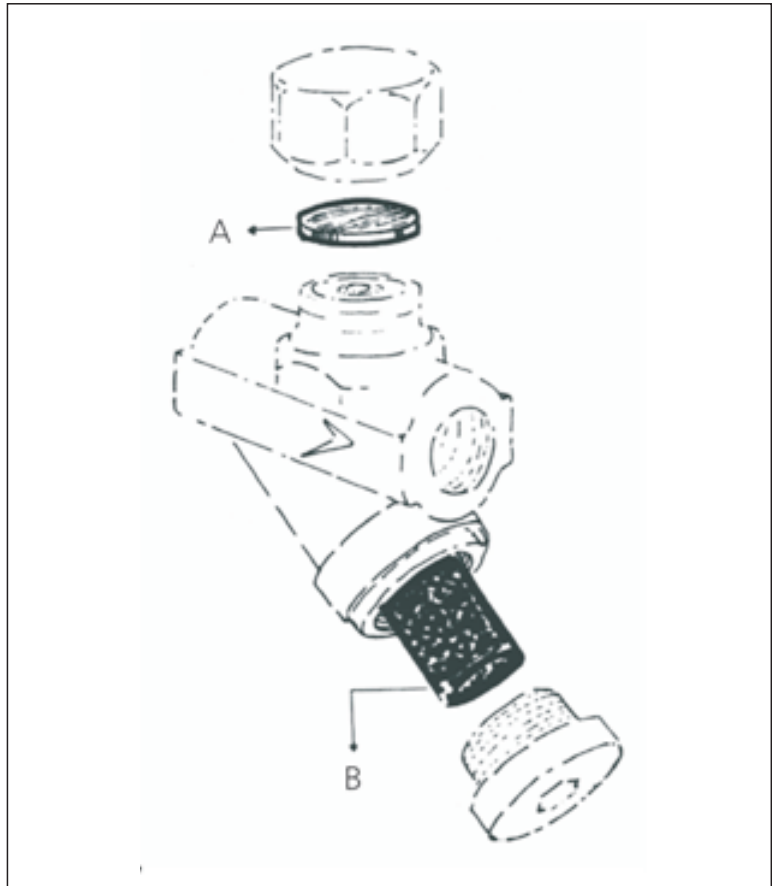

Forbes Marshall  
Krohne Marshall  
Forbes Marshall Arca  
Codel International  
Forbes Solar  
Forbes Vyncke  
Forbes Marshall Steam Systems

Forbes Marshall USA (FM USA Inc.)  
480 South California Avenue, Unit 102  
Palo Alto, CA 94306  
P: 650-327-4227  
F: 650-327-4127

Email : [fm.northamerica@forbesmarshall.com](mailto:fm.northamerica@forbesmarshall.com)

All contents herein are the property of Forbes Marshall Private Limited ("FMPL") or Forbes Marshall Steam Systems Private Limited ("FMSSPL"), as the case may be, and having protection under the intellectual property rights. Any reproduction, distribution or disclosure without prior written permission is prohibited. Information in this document is subject to change without notice.

Forbes Marshall Canada Inc.  
2425 Matheson Blvd East, 8th Floor  
Mississauga, ON L4W 5K4  
P: 905-361-2880  
F: 905-361-6401

Forbes Marshall Pvt. Ltd.  
B-85, Phase II, Chakan Indl.  
Area, Sawardari,  
Chakan, Tal. Khed.  
Dist. Pune - 410 501, India  
Tel. 91(0)2135-393400  
[www.forbesmarshall.com](http://www.forbesmarshall.com)