

# SOPT-LHX

## Steam Operated Pumping Trap - Low Head Extra Capacity

### Description

SOPT-LHX is a steam operated pumping trap with flanged connections. This innovative product is capable of working in trapping or pumping mode automatically, depending on the process conditions. The unit is operated by steam and is used to remove condensate from the process plant under all operating conditions including vacuum/stall.

### Size and Connection

Model	Condensate inlet	Condensate outlet	Motive steam inlet	Steam Exhaust
SOPT-LHX	50 NB (Class 150)	40 NB (Class 150)	15NB Screwed BSPT/NPT/BSP	25NB Screwed BSPT/NPT/BSP

### Limiting Conditions

Sizes	50 NB X 40 NB
Body design Conditions	PN16 /ASA CLASS 150
Max. Operating Pressure	13.8 bar g @198°C
Max. Operating Temperature	198°C @ 14 bar g
Min. Operating Temperature	-10°C
Discharge per cycle	6.7 Liters
Min. Required installation head from the base of SOPT-LH	200 mm
Max. Cold hydraulic test pressure	24 bar g
Max. Total Back Pressure	5 bar g

### Materials

Sr.No	Description	Material
1	SOPT-LHX BASE	SG IRON ASTM A395 / EN-JS1025
2	SOPT-LHX COVER	SG IRON ASTM A395 / EN-JS1025
3	HEX SOCKET HEAD SCREW M12	ASTM A193 B7
4	15NB MOTIVE STEAM INLET (SCREWED)	SG IRON ASTM A395/ EN-JS1025
5	25NB STEAM EXHAUST (SCREWED)	SG IRON ASTM A395/ EN-JS1025
6	MAIN FLANGE GASKET	GRAPHITE
7	INTERNAL MECHANISM	STAINLESS STEEL
8	40NB FMDCV	STAINLESS STEEL

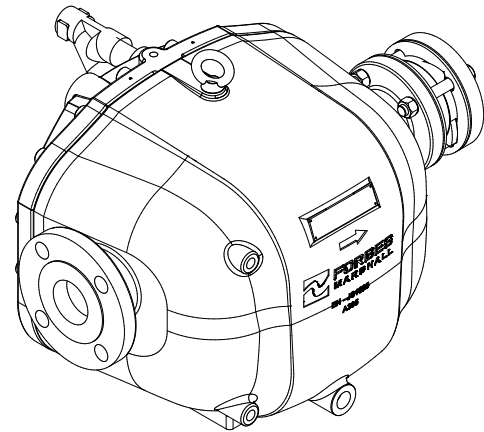

### Approx Dimensions (mm)

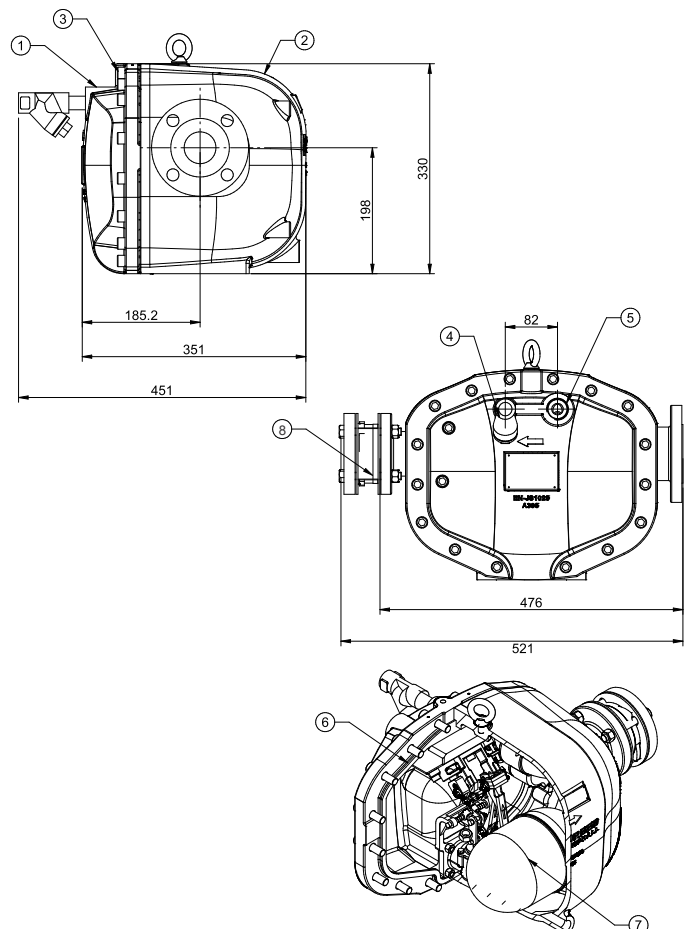

Note : Approximate dry weight = 70 Kg

Pumping Capacity Chart (For Installation Head 1000mm)		
Motive Pressure (bar g)	Total Back Pressure (bar g)	Capacity ( Kg/hr )
2	0.5	2000
3	0.5	1988
3	1	1389
3	2	869
4	0.5	2258
4	1	1759
4	2	1181
4	3	637
5	0.5	2300
5	1	1839
5	2	1217
5	3	905
5	4	609
6	0.5	2460
6	1	1997
6	2	1456
6	3	1099
6	4	912
6	5	613
7	0.5	2525
7	1	2035
7	2	1466
7	3	1099
7	4	851
7	5	743
8	0.5	2455
8	1	2173
8	2	1651
8	3	1191
8	4	901
8	5	761
9	0.5	2452
9	1	2210
9	2	1654
9	3	1150
9	4	901
9	5	740
10	0.5	2518
10	1	2130
10	2	1634
10	3	1315
10	4	927
10	5	716
11	0.5	2499
11	1	2187
11	2	1726
11	3	1385
11	4	925
11	5	735
12	0.5	2546
12	1	2229
12	2	1809
12	3	1486
12	4	1045
12	5	777
13	0.5	2538
13	1	2277
13	2	1816
13	3	1522
13	4	1010
13	5	751
13.8	0.5	2500
13.8	1	2231
13.8	2	1832
13.8	3	1511
13.8	4	1173
13.8	5	823

**Note**

Pumping capacities shown in above chart are for condensate temperature of 90° C  
 For higher back pressures & filling heads other than 1000mm contact Forbes Marshall.

**Trapping Capacity Chart**

Differential Pressure (bar g)	Capacity ( Kg / hr )
1	7000
2	8500
3	9010
5	11800
7	11800



www.forbesmarshall.com

Forbes Marshall Arca

Codel International

Krohne Marshall

Forbes Vyncke

Forbes Marshall Steam Systems

**A: Forbes Marshall Pvt. Ltd.**  
 Opp. 106th Milestone, CTS 2220,  
 Mumbai-Pune Road, Kasarwadi,  
 Pune MH 411034 INDIA  
**P: +91(0)20-68138555**  
**F: +91(0)20-68138402**

**E: ccmidc@forbesmarshall.com**

© All rights reserved. Any reproduction or distribution in part or as a whole without written permission of Forbes Marshall Pvt Ltd, its associate companies or its subsidiaries ("FM Group") is prohibited. Information, designs or specifications in this document are subject to change without notice. Responsibility for suitability, selection, installation, use, operation or maintenance of the product(s) rests solely with the purchaser and/or user. The contents of this document are presented for informational purposes only. FM Group disclaims liabilities or losses that may be incurred as a consequence of the use of this information.

**Forbes Marshall International Pte. Ltd.**  
 16A, Tuas Avenue 1,  
 #05-21, JTC Space @Tuas  
 Singapore - 639533  
**P: +65 6219 3890**

**CIN No: U28996PN1985PTC037806**