

In-situ Opacity / Dust Monitor

DCEM2100

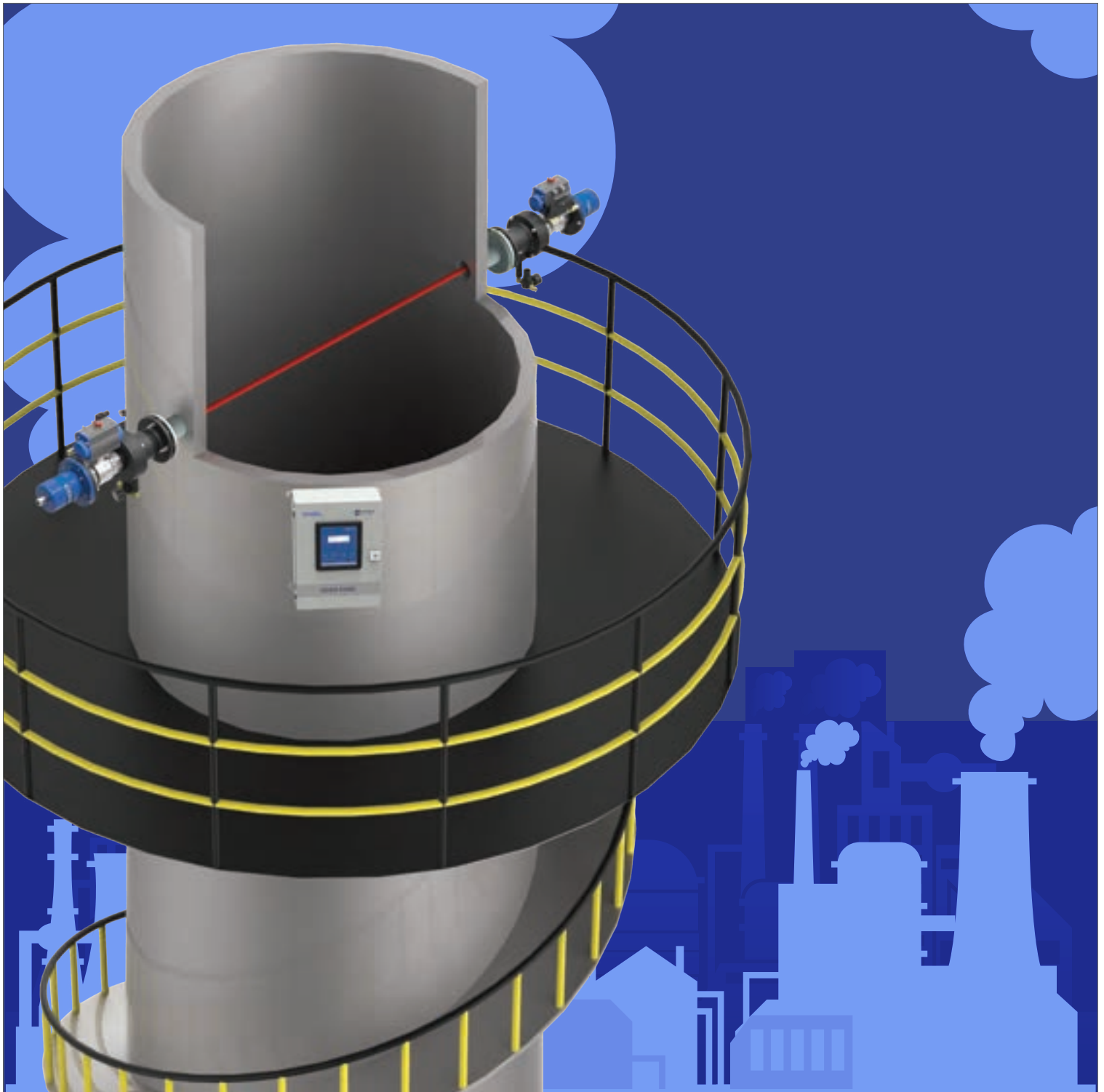

DCEM2100 In-situ Opacity/Dust Monitor

Emissions from industrial stacks are a major source of air pollution. An ever increasing emphasis across the globe today is on achieving cleaner production, driven both by stringent government regulations and in-house sustainability goals. Accurate and reliable monitoring plays a vital role in controlling emissions.

For over 75 years Forbes Marshall has been providing innovative solutions to help businesses improve their process and energy efficiency and be more environmentally responsible. Our unique dual beam twin transceiver dust monitors are the preferred globally, across sectors like thermal power, cement, steel, paper, textile, chemical, food and beverage, among others.

The DCEM2100 dual beam, open path transmissometer, our latest offering for dust monitoring provides the most accurate results by continuously measuring the transmissivity of visible light across a process duct or stack. The DCEM2100 is manufactured in collaboration with M/s Codel International Ltd., A Forbes Marshall group company.

DCEM2100 Sensor Head



The DCEM2100 monitor for measurement of opacity or dust concentration in flue gases enables plants monitor and thereby control emissions. The dual beam optical arrangement is based on twin transmissometers measuring in opposite directions through the same section of the gas stream, providing not only an accurate average of the dust loading, but also a unique dynamic assessment of any misalignment errors due to stack movement.

The LED light sources are turned on sequentially such that each transceiver measures either the transmitted light from its own source or the received light from the opposite source.

It is compact, easy to install and maintain, with auto zero and auto span calibration facility.

Features



Automatic lens contamination correction



Auto zero and span check



Dynamic misalignment check



Data displayed in % opacity, mg/m^3 , mg/Nm^3 , extinction



Built-in-fail safe shutter



Reduced footprint and wiring enabling ease of installation, commissioning and operation



Dual-pass, open-path transmissometers

Operating Principle

The DCEM2100 utilises two separate transceivers – each measuring across the same path. The LED light sources are turned on sequentially such that each transceiver measures either the transmitted light from its own source or the received light from the opposing source.

Transmissometer Dimensional Details

DCEM2100A - Instrument Air Purge Version

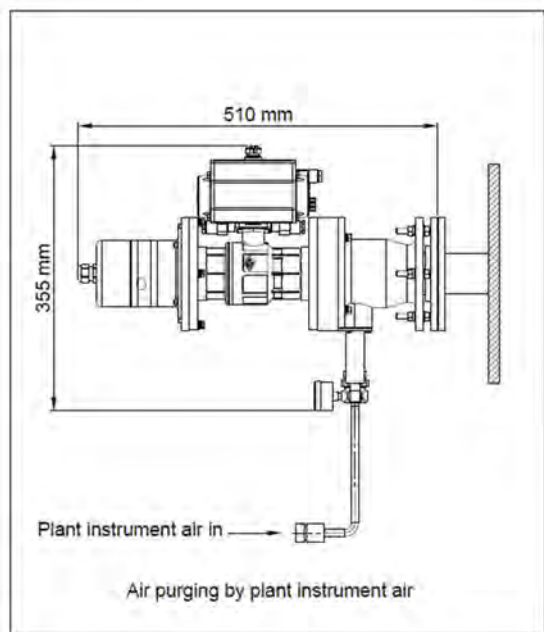

DCEM2100B - Blower Version

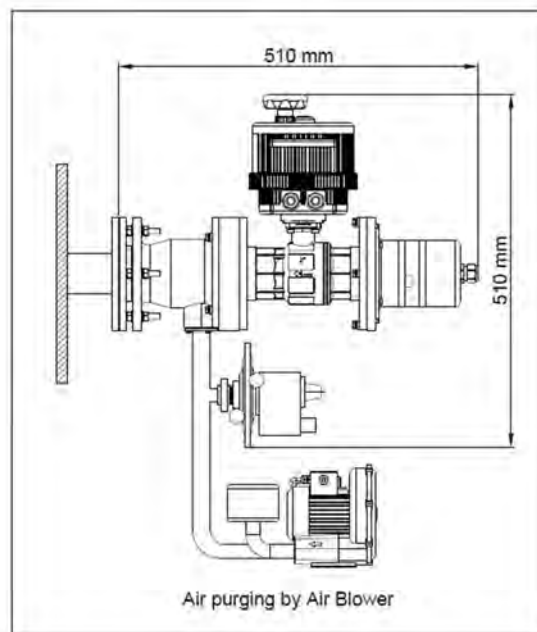

Sensor Head Dimensional Details

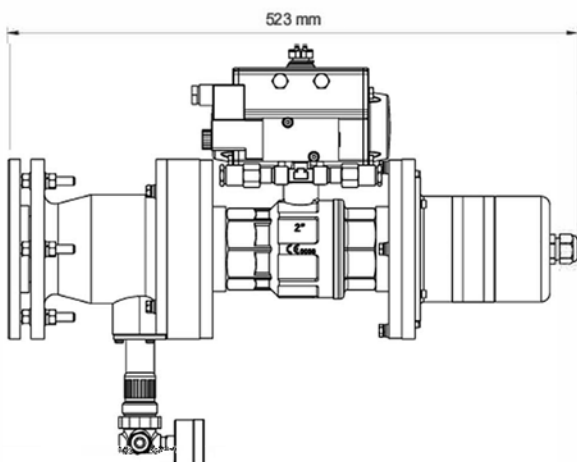
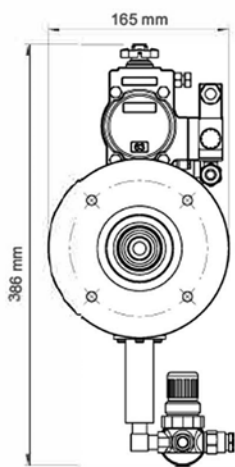

Signal Processor, Display and Control Unit and Power Supply Enclosure Details

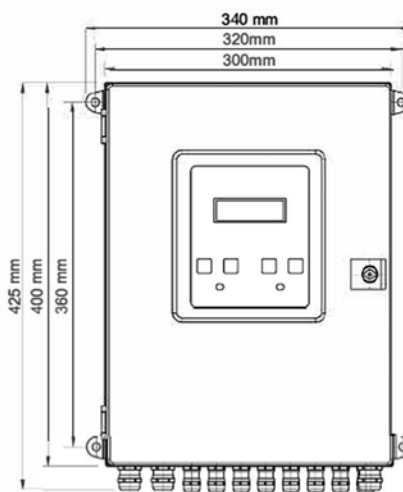

Technical Specification

Transceiver Unit

Operating Principle	Dual beam, Single pass transmissometer
Measuring units	% opacity, mg/m ³ , mg/Nm ³ , extinction
Light Source	Modulated high-intensity LED at 637nm or 580nm *
Light Detection	Continuous measurement of transmitted and received light intensities
Optical Path Length	0.5m to 6 m standard, > 6 m available on request
Accuracy	+/- 0.2% opacity FS
Response Time	10 Seconds
Measuring Range	Fully selectable in 100% opacity, 0-1000 mg/m ³ , 0-1000 mg/Nm ³ , 0-2.5 extinction
Minimum Range	0 - 10 mg/m ³
Resolution	0.1 % opacity
Linearity and Repeatability	1 % linearity, 1 % repeatability at zero and span point
Drift	<1 % opacity per month
Averaging	4 rolling averages selectable from 1 seconds to 30 days
Calibration	Periodic Auto zero and span verification check
Ambient Temperature	-20°C to + 70°C
Flue Gas Temperature	Above dew point to 600°C maximum
Power supply	24VDC from Display and Control Unit
Construction	Corrosion resistant powder coated aluminium housing sealed to IP66
Air Purge	Compressed Clean and dry compressed air, 0.5 litre/sec @ 4bar pressure
Fail-safe Shutter	Automatic shut-off valve in case of compressed air or power failure

*US EPA Compliance requires Light at 580nm; dust measurement in mg/Nm³ requires 637nm.

Signal Processor, Display and Control unit and Power Supply Enclosure

Construction	Powder coated mild steel panel IP66
Ambient Temperature	-20°C to +55°C
Outputs	2 x 4-20mA, 500 ohms, fully site configurable, 2 x RS485 MODBUS
Logic Input	2 active DI with 24 V DC source - one for plant status and the other as spare
Display	4 line x 20 Character alpha-numeric back-lit LCD
Keypad	4-key soft-touch entry
Power Supply	88 - 264VAC, single phase, UPS supply, 50/60Hz, 50VA
Alarm Contacts	3 x SPCO contact outputs, 2 for alarms, one for data invalid rated @50v/1 amp, fully site configurable

Compliances

EMI/EMC	EN/IEC61326-1
Low Voltage	73/23/EEC directive compliant
Vibration	IEC60068-2-6
Ingress protection (IP)	IP-66
TUV / MCERT	EN 15267-3 TUV/MCERT compliant

Optional Items

Optional Items	Analog input card, Pressure transmitter, Temperature transmitter
	Opacity Check Filter, Air blower unit, Remote display & Control unit

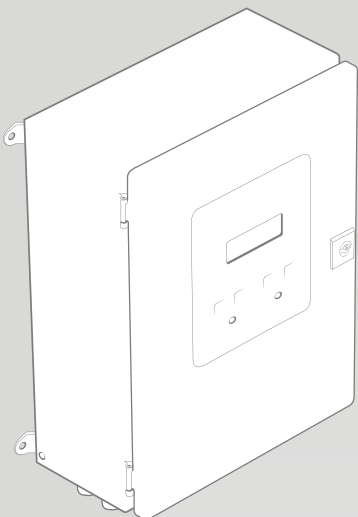

Dust Density

The outputs can be expressed in % opacity and dust density in mg/m^3 or mg/Nm^3 (corrected to standard O_2 / CO_2 , temperature, pressure and H_2O).

Purge Air Failure

An integral ball valve mounted between each transceiver and its air purge acts as an automatic shut off valve which closes on loss of power or purge air.

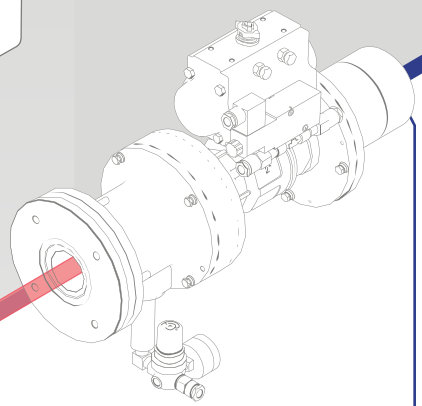

Misalignment

Optical transmissivity is measured simultaneously in opposite directions over the same gas path using identical transceivers. When optical alignment is correct these measurements are identical. Any optical misalignment produces different transmissivities. The analyser automatically detects this and raises an alarm.



Contamination

A retro mirror mounted on the ball of each auto shut off valve can be automatically rotated in and out of the optical path of each transceiver. This enables the individual window contamination to be measured and corrected for each transceiver and individual compensation applied.



High-efficiency air purges keep windows clean



Alternate, bi-directional measurement provides automatic misalignment check



Linear—not influenced by backscatter effects



Protected mirrors check individual contamination on both transceivers



Rotary valves protect transceivers during purge air or power failure

Conventional Transmissometer Vs DCEM2100

Enhanced CEMS Uptime Services

Legislative authorities mandate an uptime of 85% for continuous emission monitoring systems, with monthly, quarterly and annual reporting as per prescribed format. Regular calibration and maintenance are necessary to ensure the accuracy and reliability of the monitoring data. A record of system operation, maintenance, calibration, and reasons for downtime needs to be maintained. Forbes Marshall Enhanced CEMS Uptime Service helps plants bridge the gap between desired and actual performance through proactive health monitoring of the system and its components. An expert team works round the clock on monitoring, analysis and diagnosis of data to improve and sustain system performance.



Uptime

Increase the instrument uptime



Health

Continuous monitoring by experts on health of the instruments generating easy to follow preventive actions



Benchmarks

Highlights critical emission upsurges



Proactive Support

Suggestions and recommendations on proactive maintenance



CEMS data

transmission to CPCB / SPCB server

A Typical 250 MW Thermal Power Plant

Uptime Improvement

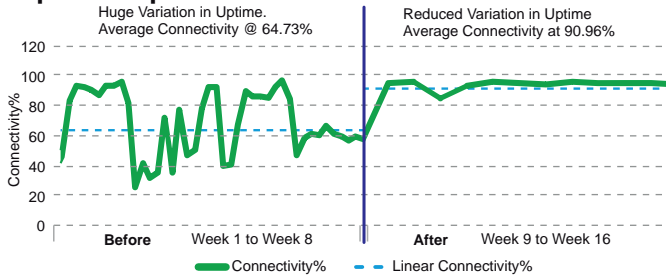

Health Improvement

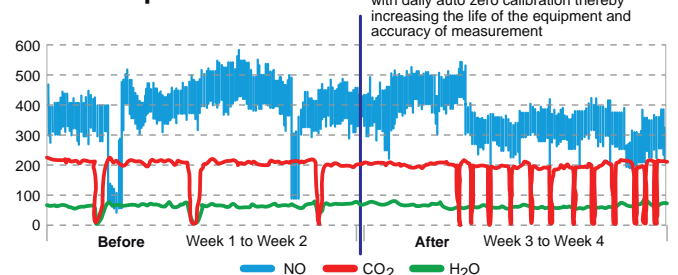

Our Other Offerings

Product and Model No.	DCEM3100 Extractive Dust Monitor	ET301 Insitu Probe	VCEM5100 Insitu Non Contact	FMGCEM40xx Gas Analyser	Oxitec 5000 Insitu Probe	ET201 Extractive
Parameters Monitored	Dust	Dust	Gas flow	CO, SO ₂ , NO _x , HCL, CH ₄	Oxygen Combustion	CO and O ₂
Purpose	Emission Monitoring	Emission and bag filter performance	Volumetric Emission	Emission Monitoring	Control and normalisation	Coal Mill / Silo / Bunker Safety
Suitable for Stack	Condensing Gases	Stack ID <4 mtr	Stack ID >0.5 mtr	Metal / Concrete stack	Stack / duct ID >0.5 mtr	Not Applicable



Forbes Marshall Pvt. Ltd.

Opp 106th Milestone, CTS No. 2220, Mumbai-Pune Road, Kasarwadi, Pune- 411034 INDIA
Tel: +91(0)20-68138555 Fax: +91(0)20-68138402

Forbes Marshall

Krohne Marshall

Forbes Marshall Arca

Codel International

Forbes Vyncke

Forbes Marshall Steam Systems

CIN No.: U28996PN1985PTC037806

Email : environ@forbesmarshall.com, ccmidc@forbesmarshall.com

www.forbesmarshall.com

© All rights reserved. Any reproduction or distribution in part or as a whole without written permission of Forbes Marshall Pvt Ltd, its associate companies or its subsidiaries ("FM Group") is prohibited.

Information, designs or specifications in this document are subject to change without notice. Responsibility for suitability, selection, installation, use, operation or maintenance of the product(s) rests solely with the purchaser and/or user. The contents of this document are presented for informational purposes only. FM Group disclaims liabilities or losses that may be incurred as a consequence of the use of this information.